



TECHNICAL CAUSES OF THE COLLAPSE OF DE LA CONCORDE OVERPASS IN LAVAL, CANADA

BENOIT BISSONNETTE, *benoit.bissonnette@gci.ulaval.ca*
Research Center on Concrete Infrastructure (CRIB)
Dept. of Civil Engineering, Laval University, Quebec City (QC), Canada

Abstract: On September 30, 2006, part of the *Boulevard de la Concorde* overpass above Highway 19 in Laval (QC), Canada collapsed suddenly, resulting in serious casualties. The Government of Quebec established a public commission of inquiry (CEVC) to investigate the circumstances of the collapse, to identify its causes, and to make recommendations. The bridge design was characterized by the use of cantilever beam seats, which were at the same time vulnerable to degradation and extremely difficult to inspect. Based on the collected evidence, the collapse was due to the development and growth of a crack in a zone prone to saturation and deterioration located under the upper rebars starting from the beam seat area of the cantilevers. There was consensus among the experts as to the main physical causes of the collapse and agreement on the following points: improper rebar detailing during design; improper rebar installation at the time of construction; and, low quality concrete used for the abutments. Based on the results of the investigation, a series of 17 recommendations were issued by the CEVC.

Keywords: Abutment, beam seat, cantilever, collapse, durability, frost resistance, reinforced concrete, shear, reinforcement.

1. Introduction

On September 30, 2006, part of the *Boulevard de la Concorde* overpass above Highway 19 in Laval (QC), Canada collapsed suddenly, resulting in the death of five people and causing injuries to six others. A few days later, the Government of Quebec established a Commission of inquiry (“Commission” or “CEVC”) to investigate the circumstances of the collapse, to identify its causes, and to recommend to the Government measures to preclude any recurrence of such events. After putting together technical and legal teams, the Commission focused on the protection and preservation of the elements of the structure needed for the investigation and collected samples for probe testing. It then commissioned scientific investigations in order to determine the causes of the collapse. It compiled and analyzed all the available documentation in order to reconstruct the life of the structure, from its design to its tragic collapse. It identified, sought out and met with the individuals and organizations involved in the design, construction and maintenance of the structure, and witnesses of the collapse. During public hearings, it heard the testimony of 58 witnesses and experts. It also consulted with persons and organizations likely to shed light on various aspects of bridge management systems. The Commission drafted a final report in the fall of 2007.

In this paper, the findings of the Commission with regards to the technical causes are summarized, together with the recommendations that were issued.

2. Characteristics of the *de la Concorde* overpass

At the time of construction, the design of the *de la Concorde* overpass was somehow innovative. The use of prestressed concrete box girders allowed to crossing Highway 19 with

a single-span deck, without intermediate supports. The box girders were installed side by side to form the bridge deck and were supported at both ends by cantilever beams extending from the abutments. The slender superstructure reduced significantly the excavation depth required for the open-cut construction of the freeway underneath.



Fig. 1. View looking to the west of the collapsed *de la Concorde* overpass, from the east abutment, on September 30, 2006

The box-girder deck rested on beam seats located at the end of the cantilevers and continuous across the full width of the bridge, directly under the expansion joints (Fig. 2). The end of the cantilever is a particularly complex load transfer area. The expansion joints are severely exposed elements that lose their ability to evacuate water when damaged, contributing to the accumulation of moisture, deicing salts and debris on the load-bearing support. The vulnerability was even greater in the present case because the seats could not be inspected and maintained without lifting the deck. To do so, traffic would have had to be interrupted on both Boulevard de la Concorde and Highway 19. The expansion joints and the ends of the cantilevers on this type of structure thereby become critical areas requiring special attention during inspections and maintenance work.

The two cantilevers were designed as thick reinforced concrete slabs. If the reinforcement detailing is inadequate or if the reinforcing bars are misplaced, the load-bearing capacity of such structure can be seriously compromised.

Besides allowing the structural RC members to resist considerable loads, steel reinforcement provides ductility. A ductile structure deforms significantly before collapse, whereas a brittle one fails suddenly, without any noticeable prior deformation. Poorly designed, incorrectly placed or insufficient reinforcement not only compromises the strength of a reinforced concrete structure, but it may also make it brittle. The concrete mixture must have the strength to provide proper anchorage for the reinforcing bars.

In order to ensure frost resistance of concrete and protect it against the effects of freeze-thaw cycles in severely exposed structures, small air bubbles are usually incorporated into the mixture during its manufacturing. The proportions of the mixture, especially the water/cement ratio, directly affect the concrete's durability and mechanical strength. If the quality is insufficient for the type of structure in which it is used, or if it is unable to resist repeated freeze-thaw cycles, the concrete will deteriorate, with serious consequences for the structure.

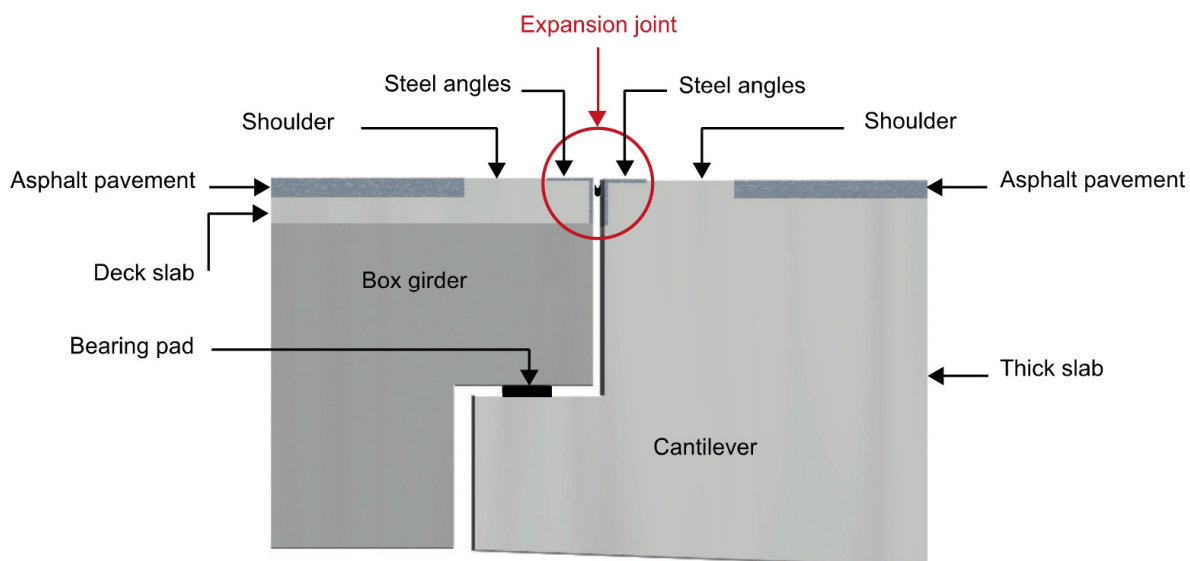

Fig. 2. Diagram illustrating the cantilever beam seat configuration

Finally, on a structure exposed to freeze-thaw cycles and de-icing salts such as a bridge, current practice calls for the installation of a waterproofing membrane to prevent the infiltration of salt brine which could deteriorate the concrete. While it was not a common practice at the time of construction of the overpass, the installation of waterproofing membranes had become current in 1992, when major repairs were performed on the bridge.

To summarize, the *de la Concorde* overpass was a unique, vulnerable structure exposed to severe conditions. Once the structure was put in service, the critical zones located at the junction of the cantilevers and the box girders needed to be carefully monitored and the expansion joints promptly repaired to prevent the infiltration of salt-contaminated water from the deck and ensuing damages. In fact, because they are virtually impossible to inspect properly, in-span beam seats were abandoned nearly 40 years ago by the Ministry of Transportation of Quebec (*MTQ*) and would not be allowed under current codes.

3. Findings of the inquiry

The evidence collected during the enquiry clearly shows that the design of *de la Concorde* overpass did not contravene any critical provisions of the applicable standards (CSA Standard S6-1966, *Canadian bridge design code*). However, the specifications regarding the type of concrete to be used were confusing and resulted in the use of low quality concrete.

The Commission found out that the overpass construction was marked by unfulfilled obligations and faulty installation. The general lack of accountability for the quality control of the work and materials was found to be the most significant weakness during construction of the overpass.

Management of the structure over its lifespan was equally found by the CEVC to be inadequate, with respect to inspection and follow-up actions. Based on the inspection reports submitted and the testimonies heard by the Commission on this matter, it was concluded that the bridge managerial staff at *MTQ* was aware of the peculiar features of the *de la Concorde* overpass, a structure with an unusual design that posed serious inspection problems. Nevertheless, CEVC identified different management miscues over the years, notably:

- the inspection and maintenance programs did not take into account the particular characteristics of the bridge, notably the critical beam seats at the ends of the cantilevers;

- scheduled maintenance activities were delayed;
- repairs carried out in 1992 were a missed opportunity to perform an assessment and repair adequately the structure;
- an opportunity to conduct a detailed evaluation was also missed in 2004, when an inspector expressed concerns about the condition of the structure.

4. Causes of the collapse

The Commission concluded that no single organization or individual could be assigned the responsibility for the collapse. None of the defects or omissions identified could have alone caused the collapse, which resulted from a chain of causes.

The tragic event of September 30, 2006, resulted from an accumulation of shortcomings: the design codes applicable at the time, which would be considered inadequate today; the design itself; the construction work; and the management of the structure during its useful life.

The collapse of the *de la Concorde* overpass stemmed from a chain of physical causes that have been identified with a high level of confidence. The experts heard by the Commission agreed on the main physical causes of the collapse. However, different opinions have been expressed as to the secondary causes. The Commission judged that some of the secondary causes were significant, in particular some human interventions, which allowed the physical circumstances of the collapse to develop.

The fact that the physical causes were not detected and addressed before September 30, 2006, raised two important questions: first, could the collapse, or at the very least, the existence of a major structural defect, have been foreseen, and was it avoidable; secondly, how did the situation get to this point?

While the collapse of the *de la Concorde* overpass occurred suddenly, the CEVC came to the conclusion that the tragedy was the culmination of a gradual deterioration that was for many years in the making. At play were both organizational and human causes that include failure to fulfill obligations and to comply with procedures, incomplete files, lack of teamwork and communication, missed opportunities for condition evaluation of the bridge, and inspection practices that did not take into account the special features of the overpass. On September 30, 2006, the *de la Concorde* overpass essentially collapsed under its own weight. For that to happen, the bridge had to have reached an advanced state of deterioration.

5. Main technical causes

Experts agreed that the overpass collapsed as a result of shear failure of the south-east cantilever. Deterioration of the concrete and not that of the rebar was behind the collapse. The collapse was due to the development and growth of a crack in a zone of weakness located under the upper rebars starting from the beam seat area. Over the years, the freeze-thaw cycles, along with de-icing salts, caused the concrete to deteriorate in this area (see Fig. 3). This deterioration caused a cracking plane to spread inside the thick slab.

While the exact source of the cracking has not been determined with certainty, there was a consensus among the experts as to the main physical causes of the collapse and agreement on the following points:

- improper rebar detailing during design;
- improper rebar installation at the time of construction;
- low quality concrete used for the abutments.



Fig. 3. Longitudinal section of the non-collapsed part of the slab showing the presence of highly deteriorated concrete on the surface of the thick slab, behind the shoulder of the joint

Improper rebar detailing during design – In the structure as designed, the concentration of numerous rebars on the same plane in the upper part of the abutment created a plane of weakness where horizontal cracking could occur. Top bars No. 14 were not anchored at the end. Detailing by today's standards would require that the No. 8 U-shaped hanger bars be hooked around No. 14 bars.

Improper rebar installation at the time of construction – There was a potential horizontal plane of weakness due to the high concentration of rebars at the top of the beam seat. The incorrect placement of the U-shaped hangers and diagonal bars created a much larger zone of weakness extending deeper inside the thick slab.

Low quality concrete used for the abutments – The expert probes showed that the concrete in the abutments did not have the necessary characteristics to resist freeze-thaw cycles in the presence of de-icing salts; the concrete was in fact highly porous and the air-void network was deficient.

As for the exact origin of the cracks, the experts pointed at a number of possible causes, including the following:

- the high bond stress between the No. 14 bars and the concrete in the area of the bearing support;
- the presence of a zone of weakness above the U-shaped hanger bars;
- concrete deterioration due to successive freeze-thaw cycles in the presence of de-icing salts;
- shrinkage of the concrete at the level of the longitudinal bars;
- the thermal stresses induced by the heat of hydration of the concrete, by solar radiation and by the placement of hot asphalt;
- the repeated traffic and vehicle impact loads on the expansion joint;
- corrosion of the No. 8 and No. 14 bars.

6. Contributing physical causes

The following causes were considered as having contributed to the collapse:

- the lack of shear reinforcement in the thick slab;
- surface of the thick slab not waterproofed;
- the damage caused during the 1992 work.

Lack of shear reinforcement in the thick slab – The thick slab of the de la Concorde overpass should have been provided with shear reinforcement if the calculations had taken into account current Code requirements. According to the experts, the shear reinforcement would have intercepted the zone of weakness and controlled the internal cracking. The collapse could then have been prevented, or at the very worst, would have occurred gradually, accompanied by noticeable deformations.

Surface of the thick slab not waterproofed – Absence of an adequate protection of the thick slab, which should have been installed during the 1992 repairs, exacerbated the deterioration of the concrete, one of the main factors that led to the collapse. In 2006, the thick slab of the cantilever had deteriorated severely in some areas. Repeated freeze-thaw cycles do not cause the concrete to deteriorate if it is not saturated with water. The need to protect concrete structures supporting roadways has long since been documented, and high-performance membranes have been included in MTQ's general specifications since 1978.

Damage caused during the 1992 work – Most experts who testified believed that the repair work performed in 1992 played a role in accelerating the growth of the critical crack already present in the mass of the cantilever. Extensive damage was noticeable during the repair works and a lot more concrete than expected had to be removed, which exposed the U-shaped hanger bars and the main No. 14 bars over a considerable length. The Commission concluded that these observations should have prompted the MTQ to evaluate the structure and shore up the cantilevers.

7. Recommendations

Upon completion of its mandate, the CEVC issued the following recommendations:

- Revise CSA-S6-2006 Code for minimum shear reinforcement in thick slabs;
- Better define concrete quality requirements;
- Improve the personnel training and the continuing education process;
- Update MTQ manuals;
- Develop a competence-based policy for granting consulting engineering mandates;
- Implement a structural design validation policy;
- Implement a pre-qualification system for contractor selection;
- Require to be informed of key personnel changes during projects;
- Exert a better control over the sub-contracting process;
- Implement an inspection and acceptance process when projects are delivered;
- Conduct performance evaluation at the end of projects;
- Review the MTQ's organizational culture and work methods;
- MTQ to keep complete records;
- MTQ to clarify the responsibilities within its organizational chart;
- MTQ to add requirements in its inspection manuals;
- Clarify accountability for the bridges falling under municipal jurisdictions;
- Government of Quebec to make bridge rehabilitation a national priority, guided by a set of identified principles.

Reference

1. Report of the Commission of inquiry into the collapse of a portion of the de la Concorde overpass, CEVC, Government of Quebec, Canada, 222 p. http://www.cevc.gouv.qc.ca/UserFiles/File/Rapport/report_eng.pdf